

Volume 2 AMENDMENT No. 8

Date of issue: October 2022.

After the publication of 'Wireless for the Warrior' Volume 2, a small number of minor (typing) errors and incorrect data was spotted. Corrections, additional photos and newly found items are published in 'Volume 2 Amendments'. Double side printed on A4 paper, cut away circa 7 mm from the bottom and side of the sheet. The prepared sheets will fit snugly between the inside cover and dust cover flap. If applicable, it is further suggested to amend the text corrections in the book with e.g. a (red) pencil or a fine-liner.

Inductance, Aerial Tuning No. 1, its use with other equipment.

Amendment No. 8 shows two applications of Inductance, Aerial Tuning No. 1 (originally developed and produced for Wireless Set No. 19 high power), fitted in other wireless stations. Replacing Aerial Coupling Equipment, Set Unit H, probably for non availability, it was used in conjunction with Wireless Sender No. 12 in a Truck, 15-cwt 4-wheeled

Wireless Type 1. The tuning inductance No. 1 allowed to load the No. 12 Set correctly into a 12ft aerial when working on the move. The inductance was also used in a (believed interim) Truck 15-cwt wireless station incorporating an Air Ministry T1154 transmitter and a R106 receiver to match the vertical 16ft twin aerial.

It is unknown is how many of these stations came actually in use.

[When at a much later stage the Inductance, Aerial Tuning No. 1 used with WS 19 HP had shortage issues, it was substituted by Aerial Coupling Equipment, Set Unit J, described in Amendment No. 9].

Truck 15-cwt 4-wheeled Wireless Type 1 Fitted with WS No. 12/R107

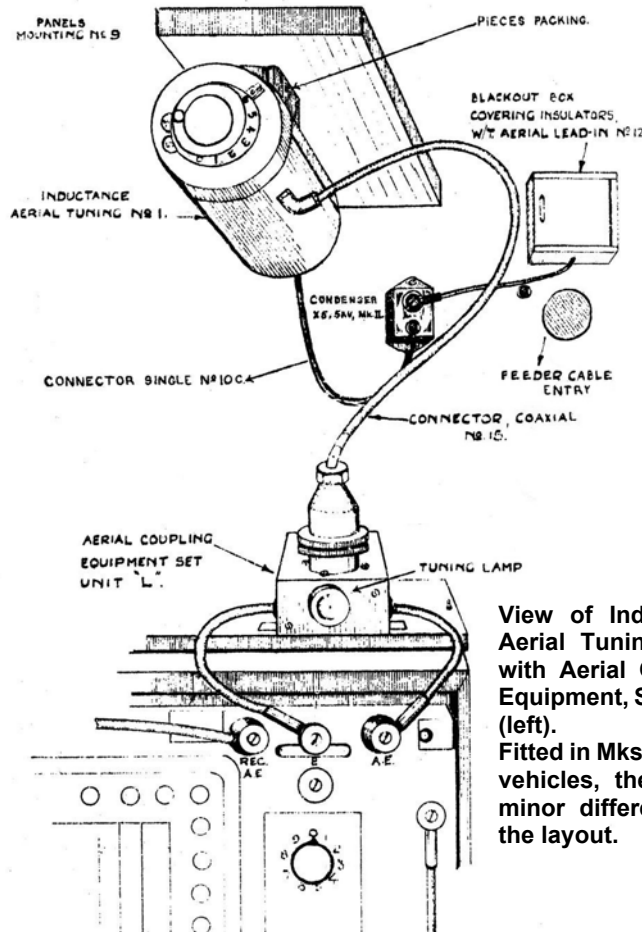
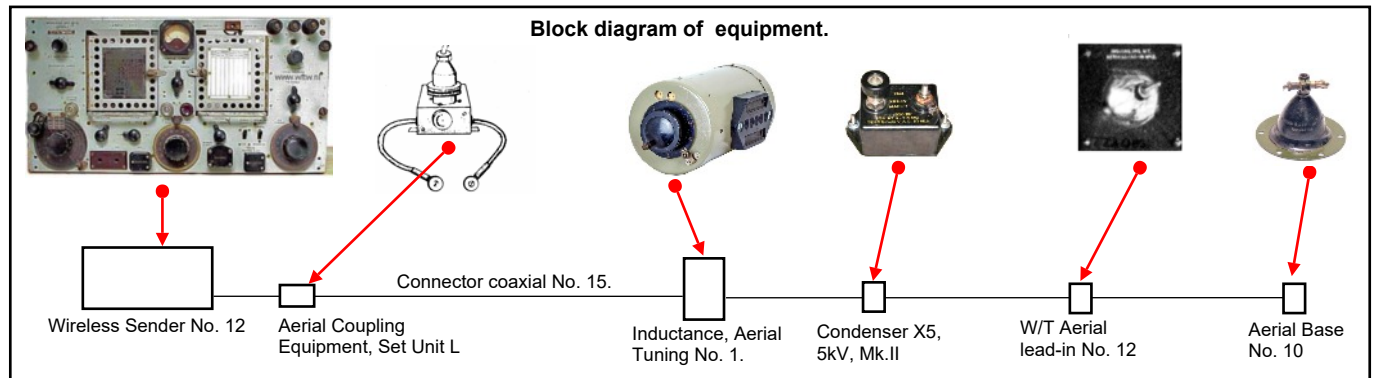

Aerial Coupling Equipment, Set Unit L, was principally an Aerial Coupling Equipment, Set Unit F, in a slightly larger enclosure fitted with a tuning lamp. It connected the Wireless Sender No. 12 to the Inductance, Aerial Tuning No. 1 via Connector Coaxial No. 15. Note the blackout box covering the glass aerial lead-in insulator No. 12, and a separate feeder cable entry below.

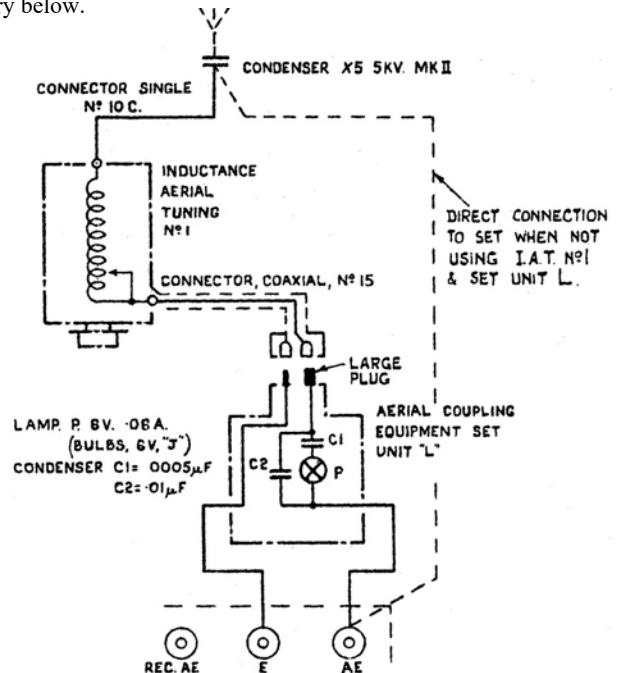

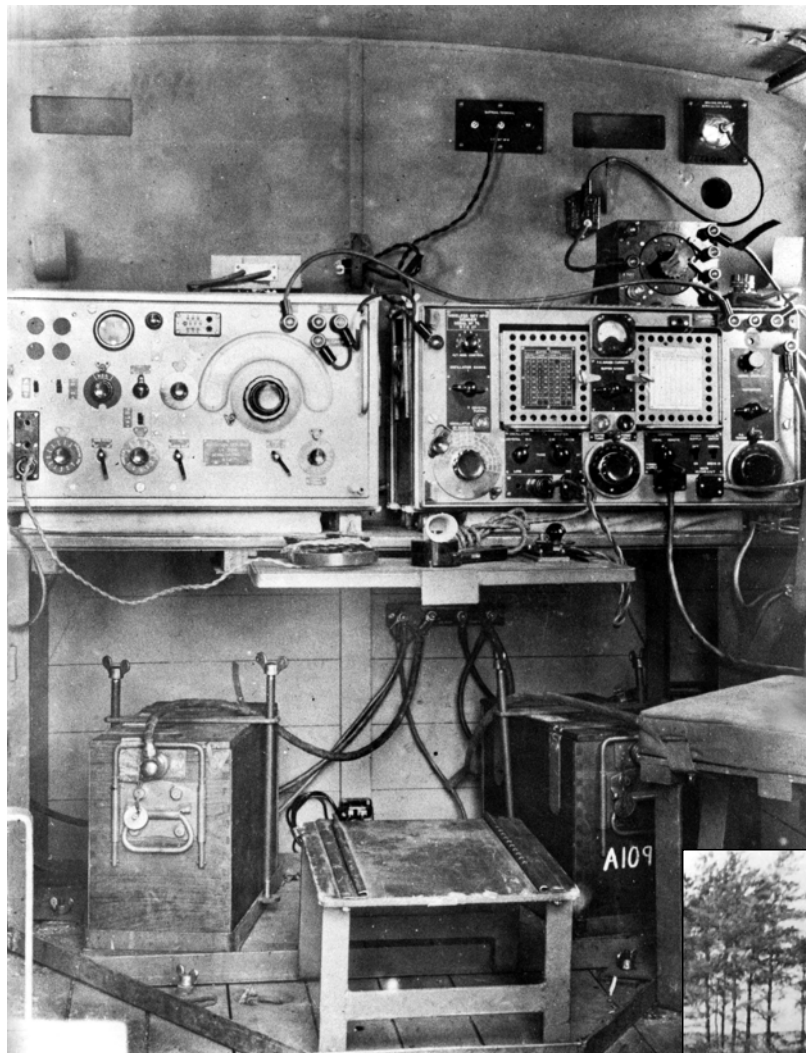

The operator's table and seat assembly (seat temporarily detached for taking this photo) could be removed from the vehicle for use as a ground station.

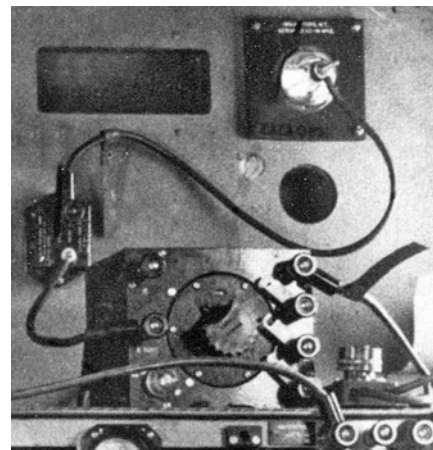

Enlarged cut-out showing Aerial Coupling Equipment, Set Unit H, Condenser X5, Insulator W/T No. 12 and feeder cable entry.

The photograph at the left hand side shows the original installation of a No. 12 Sender with Reception Set R107 fitted in a Truck, 15-cwt 4-wheeled Wireless No.1, Mk.IIb, with a wooden house body. For operation on the move Aerial Coupling Equipment Set Unit H was used to match the rod aerial on frequencies below 6MHz. The costly and laboriously to produce Set Unit H was later replaced by a standard production Inductance, Aerial Tuning No. 1, originally developed for use with the WS No. 19 high power amplifier RF No. 2.



Photo right hand side: Truck, 15-cwt 4-wheeled wireless No. 1 Mk.I. This photo was probably taken later, still fitted with the existing Aerial Base No. 3 on the roof,

and remnants of the original collapsible roof aerial No. 2 with four horizontal sections. The vehicle was a Morris, 15-cwt 6-cylinder CS8 chassis on which was mounted a special wooden body designed to house a complete mobile wireless station. There were various Marks and fitting variations of this particular vehicle, which may possibly be the subject of a future Amendment.



Condenser X5, 5kV was a multi purpose item used in vehicles to guard against accidental contact with overhead power lines.



Inductance, Aerial Tuning No. 1, developed for and normally used with Wireless Set No. 19 high power.

References

- Photographs and drawings courtesy Royal Signals Museum, Blandford Forum, U.K.
- Photograph of Inductance, Aerial Tuning No. 1 courtesy Jan Poortman, PA3ESY.
- Wireless for the Warrior, Vol. 1, Chapter WS 12, L. Meulstee, 1995, isbn 1898805 08 3.
- Wireless for the Warrior, Vol. 2, Chapter WS19HP, L. Meulstee, 2001, isbn 1898805 10 5.
- Wireless for the Warrior, Compendium 1, 'Spark to Larkspur'. L.Meulstee, 2009, isbn 978-90-808277-2-1.
- Wireless Set No. 12, General description and working instructions, ZA3047, WO Code Nr. 1049, n.d.
- WS No. 12 Send-recv on the move in truck 15-cwt. Wireless, SRDE Handbook 332, July 1942.
- Inductance, Aerial Tuning No. 1, Fitting Instructions, SRDE Provisional Pamphlet No. 332A, Addendum No. 1, n.d.
- WS No. 12 in truck 15-cwt. 4 wheeled wireless, SRDE Handbook 337, July 1942.
- Inductance, Aerial Tuning No. 1, Working Instructions, SRDE Provisional Pamphlet No. 337A, Addendum No. 1, n.d.
- Trucks, 15-cwt 4 wheeled, Wireless No. 1, Mods instr. (Wireless Station No. 12), EMER Tels L No. 157/1, Aug. 1942.
- Truck 15-cwt Wireless Stations T1154/R106, Working Instructions, SRDE Provisional Pamphlet No. 399A, Dec 1943.
- Data book of wheeled vehicles ('B' and RASC), Fourth edition, T.T.2, Ministry of supply, n.d.

Truck 15-cwt 4-wheeled Wireless Type 1 Mk.III Fitted with T1154/R106

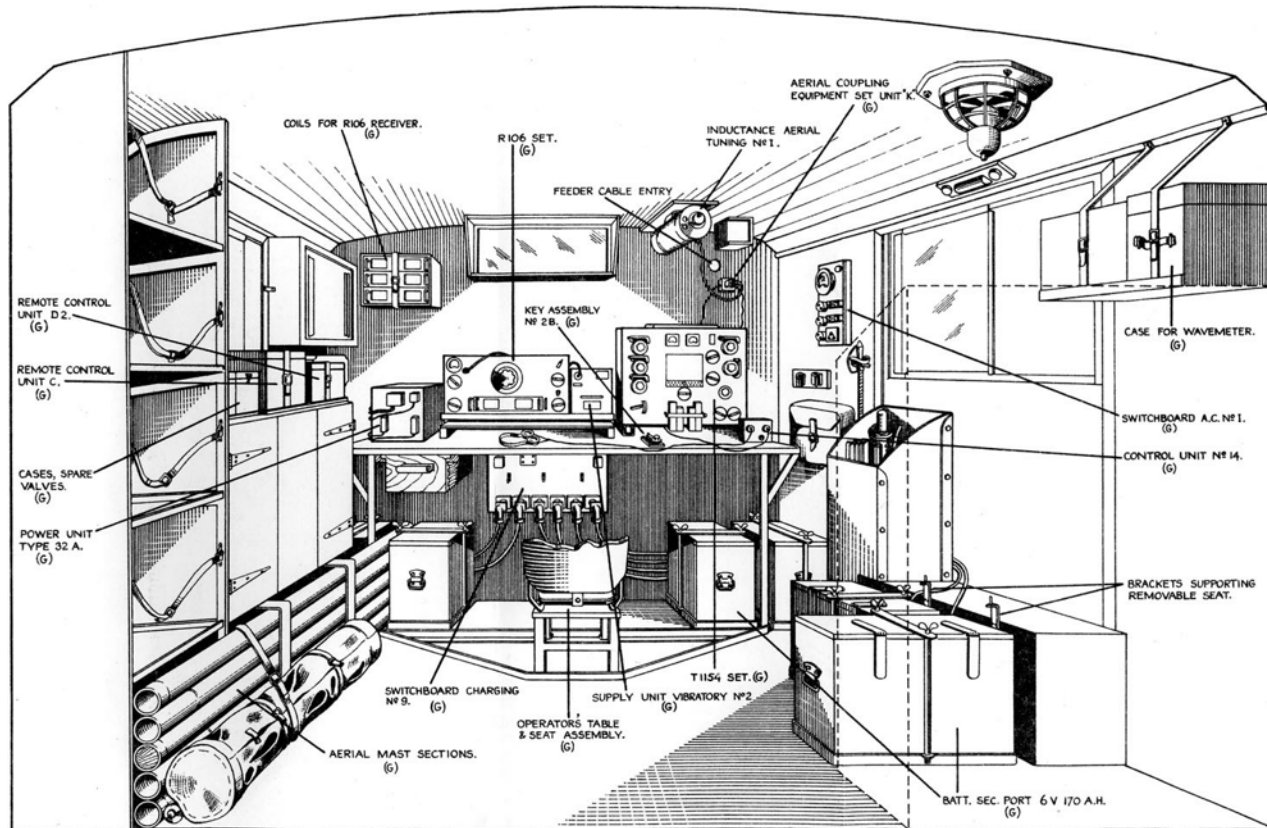

Fitted in a Truck 15-cwt, 4-wheeled Wireless, No. 1 Mk.III was a low power mobile wireless station incorporating transmitter Air Ministry (A.M.) T1154B and Reception Set R106. The station included an operator's table and seat assembly which was easily removable from the vehicle for use on the ground or in a building. Headphones and Morse key were connected to Control Unit No. 14 which incorporated the transmit-re-

ceive switch. Considering the absence of a microphone and microphone plug in the drawing above, the station was suitable for CW or MCW transmitting only. For operation on the move a 16ft aerial twin was fitted. Providing correct matching of this aerial to the T1154B at low frequencies (3-7MHz), Inductance, Aerial Tuning No. 1 was employed for series aerial loading. The transmitter was tuned to maximum brilliance of a

bulb fitted in Aerial Coupling Equipment, Set Unit K. Air Ministry transmitter T1154B was originally designed for fitting into aircraft. It is believed that when obsolete B models became available, these were used to fill a gap as temporary replacement of a WS No. 12/R107 station. No confirmation, however, of this has been found to date.

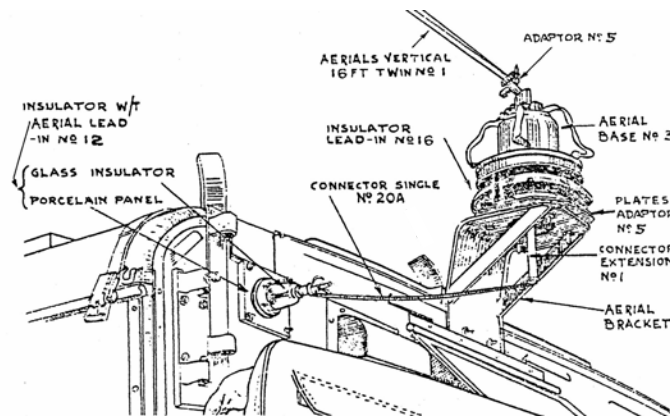

Fitting of vertical twin rod aerial and aerial base with aerial lead insulator W/T No. 12 in Truck 15-cwt No. 1 Mk.III.

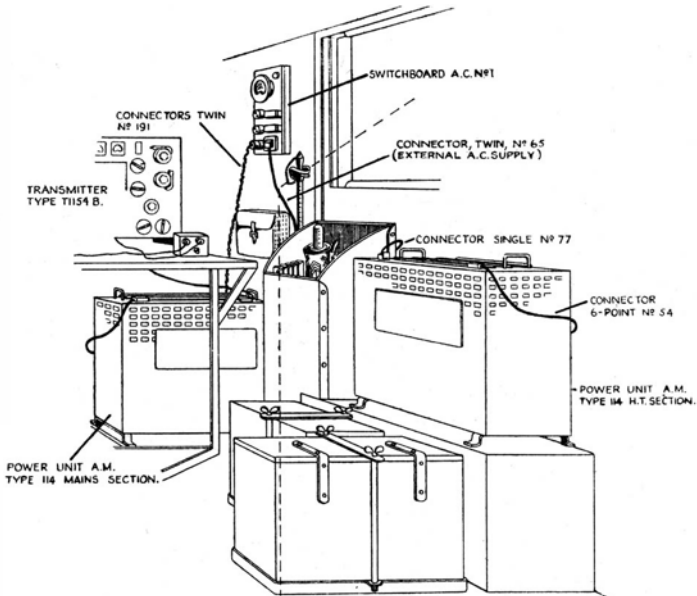

Air Ministry T1154.
On this photo is a later T1154N transmitter which was the steel version of the obsolescent T1154B having different types of click-stop mechanisms.



The seat fitted to the offside wheel arch was removed from this position making room for two batteries and AC mains power unit A.M. Type 114 (HT section for T1154). AC mains power unit A.M. Type 114 (LT section) was mounted below the operator's table below the T1154B.